

TX-6070RGLACP50FC120-NUVENG-01

PRODUCT SPECIFICATION

Features:

- ◆Excellent transiting heat from LED chip operating under P:IF=0.7A R/G/B/L/A/C:IF=1.0 A
- ◆High luminous output
- ◆Encapsulated materials are environmentally certified and meet environmental requirements.

Chip Material:

- ◆Red:AlInGaP
- ◆Green: GaInN
- ◆Blue:GaInN
- ◆Lemon light:GaInN
- ◆PC Amber:GaInN
- ◆Cyan:GaN
- ◆Purple:GaN

Emitting Color:

- ◆Red (R)
- ◆Green (G)
- ◆Blue (B)
- ◆Lemon light (L)
- ◆PC Amber (A)
- ◆Cyan (C)
- ◆Purple (P)

Applications:

- ◆Auxiliary lighting
- ◆Ambient lighting
- ◆Architectural lighting
- ◆Entertainment lighting
- ◆Stage lighting

Package Dimensions:

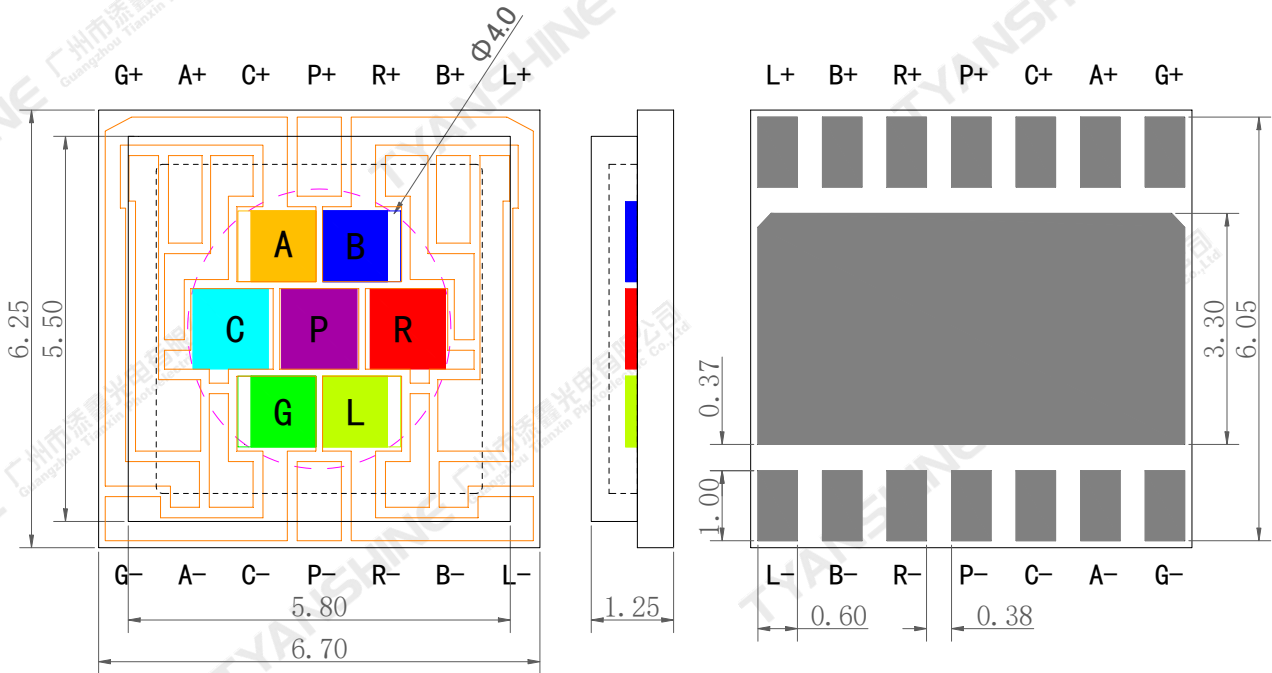

Notes:

- 1.All dimensions are in millimeters .
- 2.Tolerances unless otherwise mentioned are $\pm 0.1\text{mm}$.

Absolute Maximum Ratings (Tc=25°C)

Parameter	Symbol	Max Ratings	Unit
Forward Current	R	1.8	A
	G	2.5	
	B	2.5	
	L	2.0	
	A	2.0	
	C	1.8	
	P	0.7	
Reverse Voltage	V _R	Not designed for reverse operation	V
Power Dissipation	R	5.4	W
	G	9.0	
	B	9.0	
	L	7.2	
	A	7.2	
	C	6.4	
	P	2.6	
Junction Temperature	R	115	°C
	G	150	
	B	150	
	L	150	
	A	150	
	C	150	
	P	150	
Electrostatic Discharge Threshold (ESD)	ESD	2000	V
Storage Temperature(Only for LED, not including packaging)	T _{stg}	-40~+85	°C
Operation Temperature	T _{opr}	-40~+85	

Notes:

- Specifications are subject to change without notice.
- The data on this specification is for reference only and the actual data is in accordance with the acknowledgment.
- Precautions for ESD:
STATIC SHIELD Electricity and surge damages the LED. It is recommended to use a wrist band or anti-electrostatic glove when handling the LED. All devices, equipment and machinery must be properly grounded.

Electrical Optical Characteristics (Tc=25°C)

Parameter	Symbol	Condition	Emitting Color	Min.	Typ.	Max.	Units
Luminous Flux	ϕ_v	If=1A	R	115	—	145	lm
			G	220	—	290	
			B	35	—	52	
			L	340	—	400	
			A	170	—	210	
			C	95	—	125	
Radiant Flux	ϕ_e	If=0.7A	P	600	—	850	mW
Dominant Wavelength	λ_d	P:If=0.7A R/G/B/L/A/C: If=1A	R	620	—	630	nm
			G	525	—	535	
			B	448	—	458	
			L	565	—	570	
			C	485	—	495	
			P	425	—	430	
Correlated Colour Temperature	CCT	If=1A	L	4250	—	4500	K
			A	1750	—	1830	
Peak-emission Wavelength	λ_p	P:If=0.7A R/G/B/L/A/C: If=1A	R	625	—	635	nm
			G	520	—	525	
			B	448	—	453	
			L	545	—	560	
			C	482	—	488	
			P	393	—	398	
Spectral Line Half-Width	$\Delta\lambda$	P:If=0.7A R/G/B/L/A/C: If=1A	R	12	17	22	nm
			G	28	33	38	
			B	14	19	24	
			L	106	111	116	
			A	85	90	95	
			C	22	27	32	
			P	11	16	21	
Forward Voltage	V_f	P:If=0.7A R/G/B/L/A/C: If=1A	R	2.0	2.5	3.0	V
			G	2.8	3.2	3.6	
			B	2.8	3.2	3.6	
			L	2.8	3.2	3.6	
			A	2.8	3.2	3.6	
			C	2.8	3.2	3.6	

			P	3.0	3.4	3.8	
Reverse Current	I_R	$V_R=5V$	—	—	—	—	μA
Viewing Angle at 50 % IV	$2\theta_{1/2}$	—	—	—	120	—	Deg
Thermal Resistance Junction to Case	$R\theta_{J-C}$	P:If=0.7A R/G/B/L/A/C: If=1A	R	—	2.9	—	K/W
			G	—	2.9	—	
			B	—	2.9	—	
			L	—	2.9	—	
			A	—	2.9	—	
			C	—	2.9	—	
			P	—	3.9	—	
Temperature Coefficient of Voltage	$V\Delta F/T$	P:If=0.7A R/G/B/L/A/C: If=1A	R	—	-3.65	—	mV/°C
			G	—	-1.02	—	
			B	—	-0.65	—	
			L	—	-0.67	—	
			A	—	-1.98	—	
			C	—	-3.52	—	
			P	—	0.33	—	

Notes:

- 1.Luminous intensity is measured with a light sensor and filter combination that approximates the CIE eye-response curve.
2. $\theta_{1/2}$ is the off-axis angle at which the luminous intensity is half the axial luminous intensity.
- 3.The dominant wavelength (λ_d) is derived from the CIE chromaticity diagram and represents the single wavelength which defines the color of the device.
- 4.Luminous flux measurement tolerance:±15%.
- 5.Forward voltage measurement tolerance:±0.15V.

White light Color coordinate filing (If=1A, Tc=25°C)

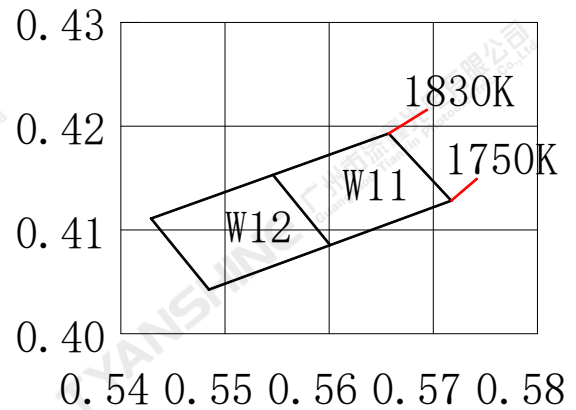
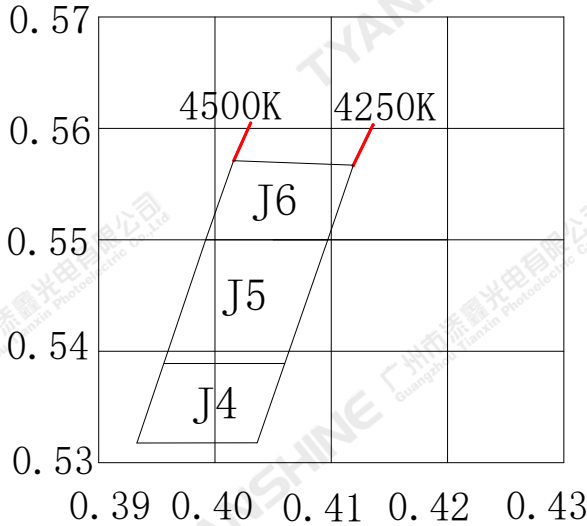

Grade	TC	P1		P2		P3		P4	
		X1	Y1	X2	Y2	X3	Y3	X4	Y4
J4	4250-4500K	0.3933	0.5318	0.3956	0.5389	0.4060	0.5389	0.4036	0.5318
J5	4250-4500K	0.406	0.5389	0.4097	0.55	0.3992	0.55	0.3956	0.5389
J6	4250-4500K	0.4097	0.55	0.4119	0.5567	0.4016	0.5571	0.3992	0.55
W11	1750-1830K	0.5546	0.4154	0.56	0.4088	0.5718	0.413	0.5658	0.4194
W12	1750-1830K	0.5429	0.4112	0.5485	0.4044	0.56	0.4088	0.5546	0.4154

Typical Electrical/Optical Characteristics Curves

(25°C Ambient Temperature Unless Otherwise Noted)

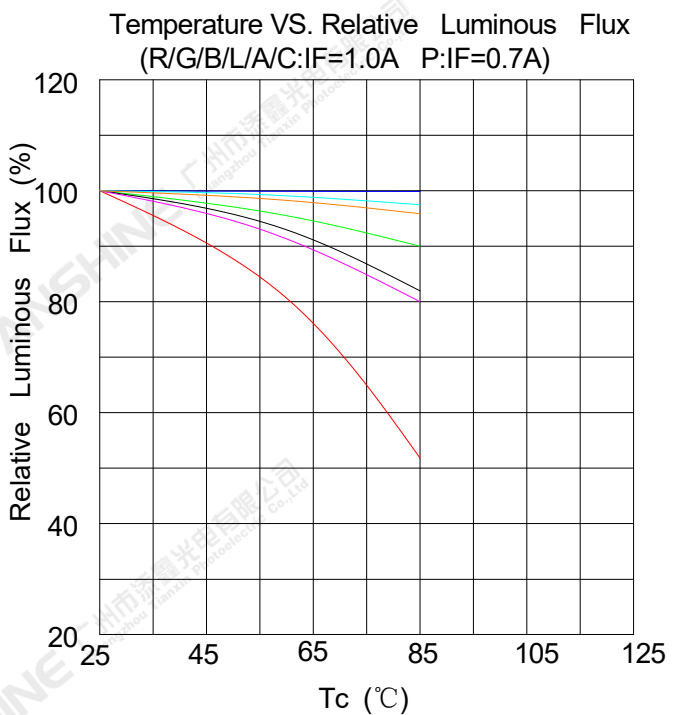
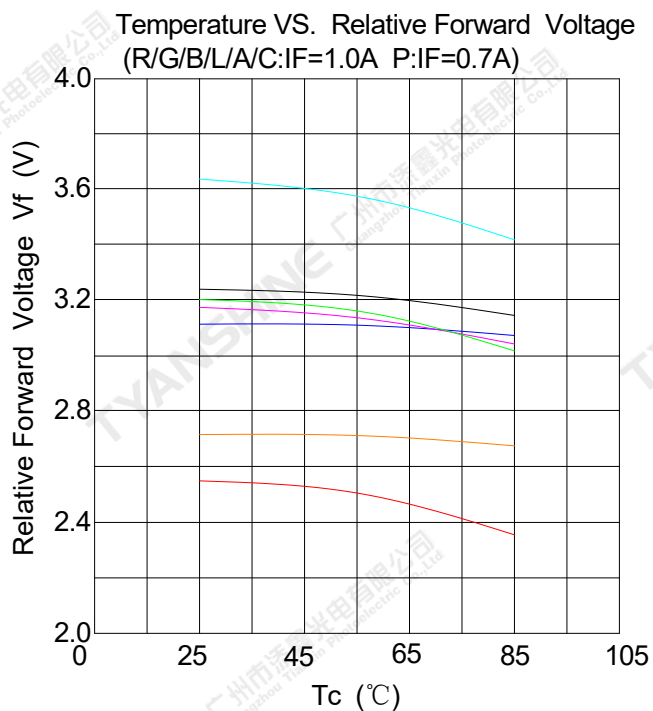
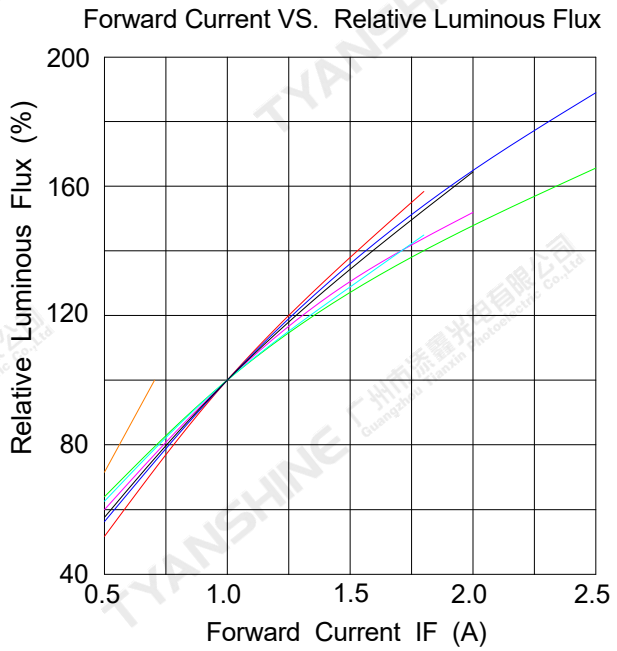
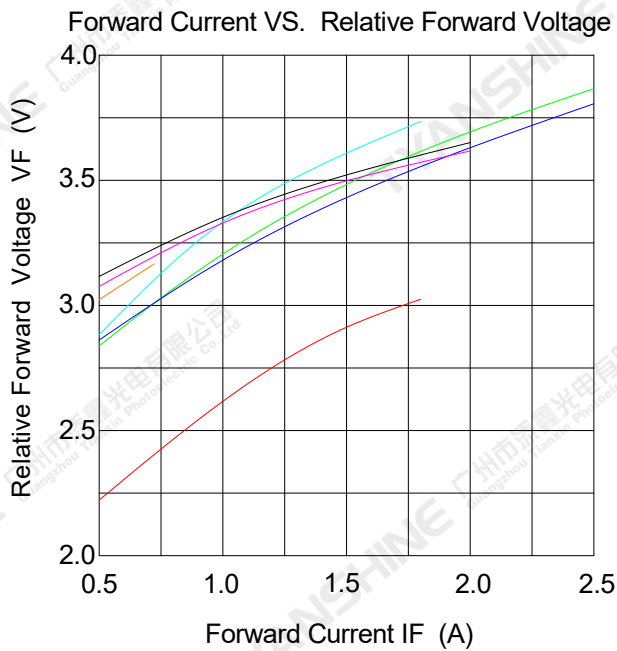

Notes: Red; Green; Blue; Lemon light; PC Amber; Cyan; Purple;

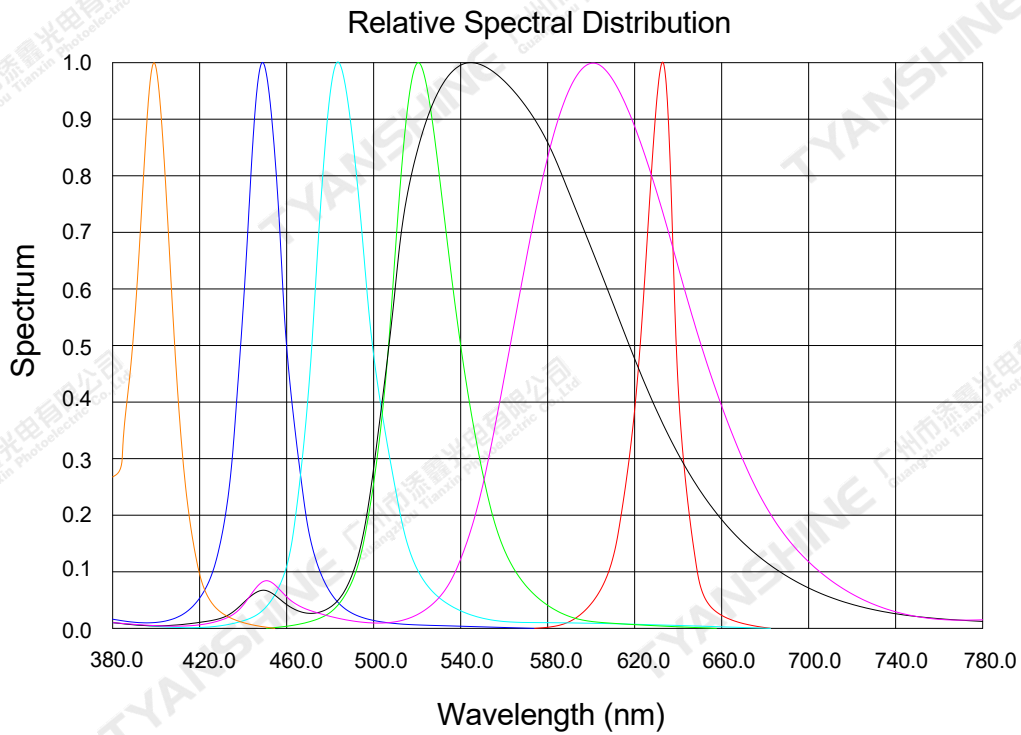

Notes: — Red; — Green; — Blue; — Lemon light ; — PC Amber; — Cyan; — Purple;

Notes:

1. $2\theta_{1/2}$ is the off axis angle from lamp centerline where the luminous intensity is 1/2 of the peak value.
2. View angle tolerance is $\pm 5^\circ$.

Usage Precautions

Storage Environment Condition

Temperature: 5°C ~ 30°C (41°F ~ 86°F)

Humidity: 60% RH Max.

Soldering Condition

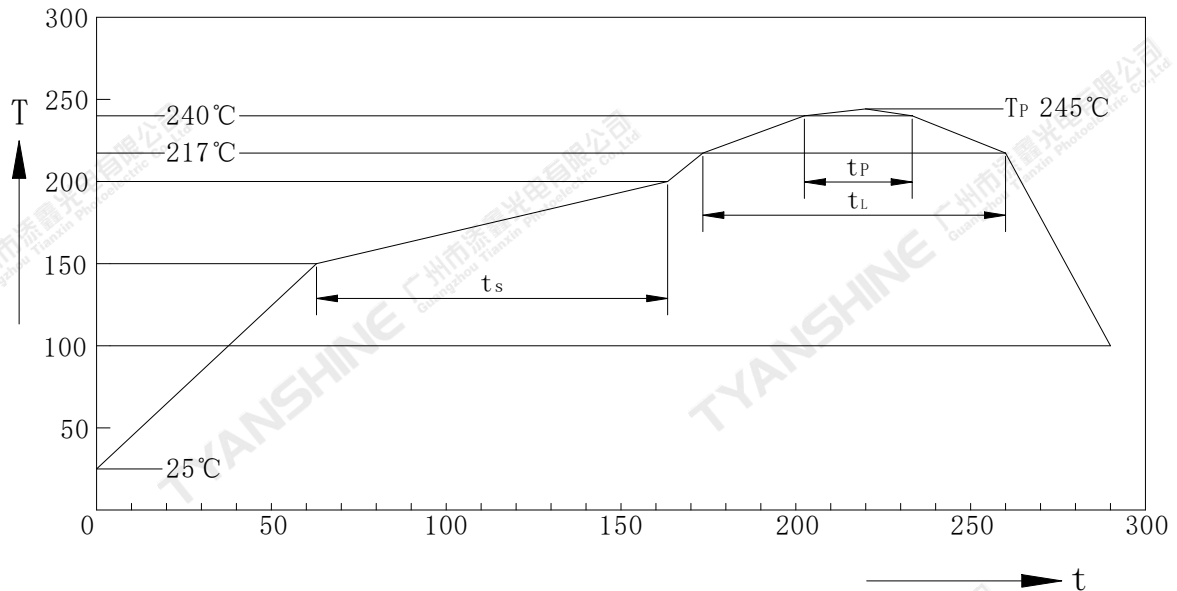

Profil-Charakteristik Profile Feature	Symbol	Pb-Free(SnAgCu)Assembly			Einheit Unit
		Minimum	Recommendation	Maximum	
Ramp-up Rate to Preheat 25°C to 150°C	-	-	2	3	K/s
Time ts T _{Smin} to T _{Smax}	ts	60	100	120	s
Ramp-up Rate to Peak T _{Smax} to T _p	-	-	2	3	K/s
Liquidus Temperature	T _L	217			°C
Time above Liquidus temperature	t _L	-	80	100	s
Peak Temperature	T _P	-	245	255	°C
Time within 5°C of the specified peak temperature T _p -5 K	t _p	10	20	30	s
Ramp-down Rate T _p to 100°C	-	-	3	6	K/s
Time 25°C to T _p	-	-	-	480	-

Note:

All temperatures refer to topside of the package, measured on the package body surface.

Dimensions For Cannulation And Packaging

Quantity: 1000PCS

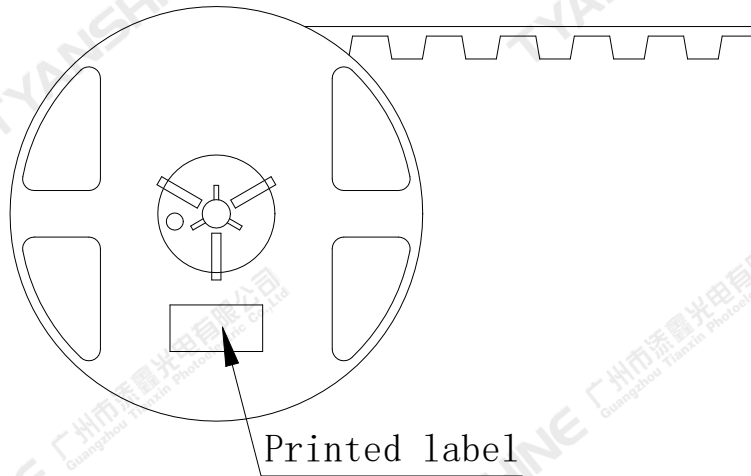
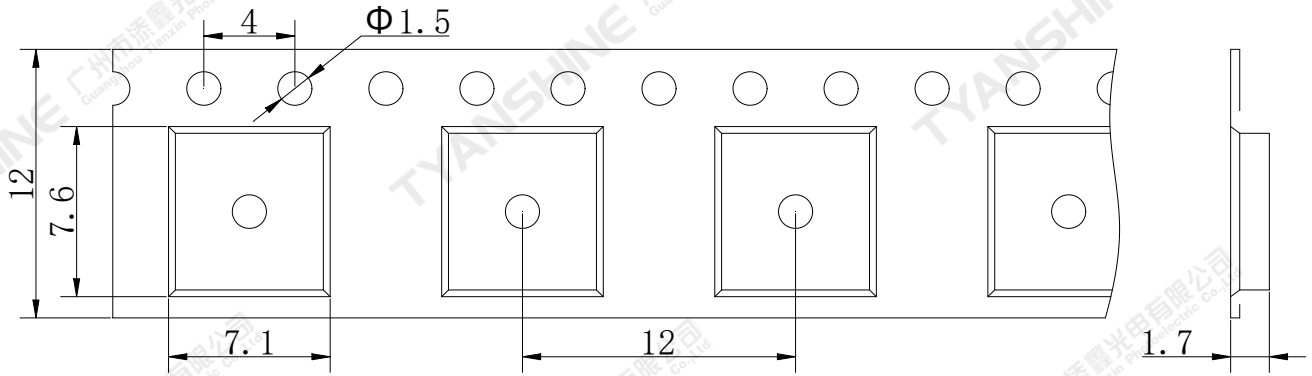

Notes:

1. All dimensions are in millimeters.
2. Tolerances are ± 2.0 mm unless otherwise noted.
3. The products are packaged together with silica gel, Transport, not to the weight of welding LED light-emitting area, As a result of the weight of LED light-emitting zone in the quality of, Irresponsible of the Company.

产品规格书变更履历表

版本	变更内容描述		生效日期
	变更前内容	变更后内容	
1.0	初次发行	-	